

PRODUCT DATASHEET

Electrical testing accordance with:
 《GB/T5968-2011》
 《GB/T5966-2011》
 LCA standard test

Do not Scale this Drawing
 Unit : mm

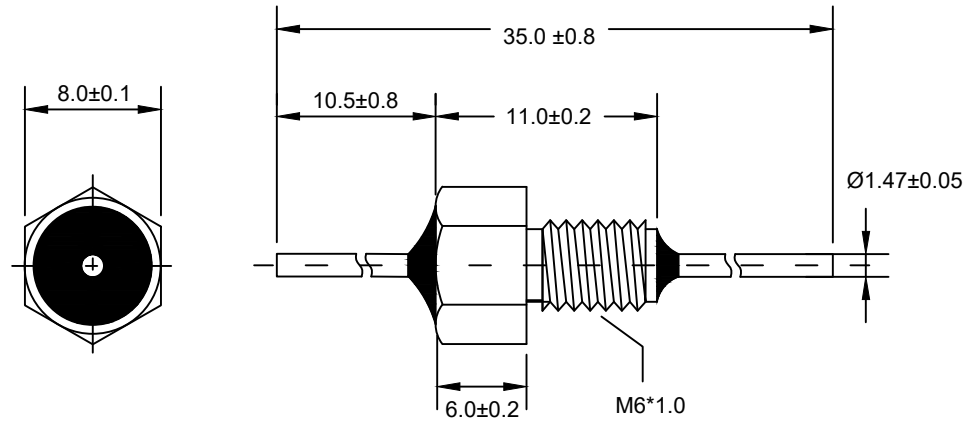
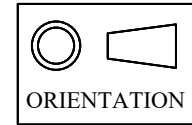

Capacitance	Cap. Tolerance	Dissipation Factor	Rated Voltage	D.W.V.	Rated Current(A)	I.R.(100VDC)	Temp. Coef.	Temp. Range				
0.01uF	-20%+20%	≤3.5%	500VDC	1250VDC	20	≥3000MΩ	X7R	-55℃+125℃				
Min. No Load Insertion Loss (dB)@25℃							Install Torque	Soldering Temp	CIRCUIT			
10KHz	100KHz	1MHz	10MHz	100MHz	1GHz	10GHz			≤300℃/3S	C		
--	--	4	20	38	50	57	0.9N·m					
Material and other parameter note: 1. The case material is nickel-plated brass, and the lead material is silver-plated brass. 2. Encapsulated with epoxy resin. 3. The above data is measured under 25℃ conditions, and the electrical performance test frequency is 1KHz/1V. 4. It is recommended to use a soldering iron for soldering. Immersion soldering is strictly prohibited, and the capacitor body must not be struck with hard objects.						Revision Record	200624-01		Product Series		Thread Mount Feedthrough Filters	
							260119-01		LCA [®] made in China		L8060-044N	