

PRODUCT DATASHEET

Electrical testing accordance with:
 《GB/T5968-2011》
 《GB/T5966-2011》
 LCA standard test

Do not Scale this Drawing
 Unit : mm

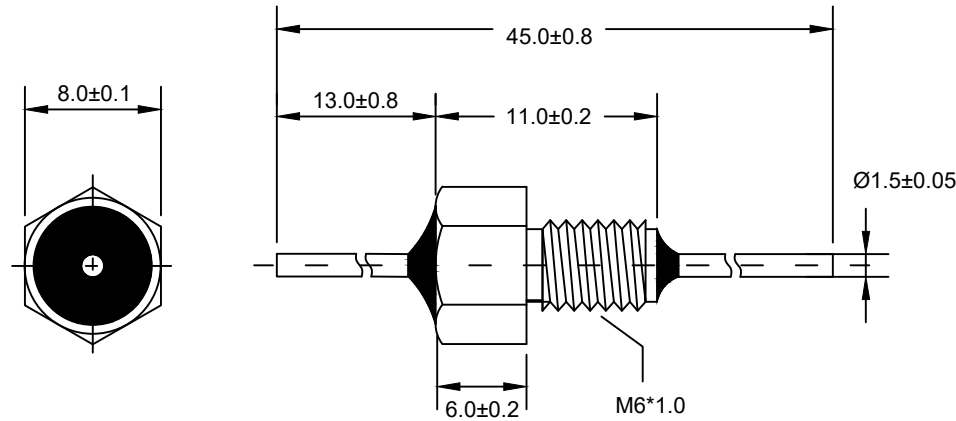
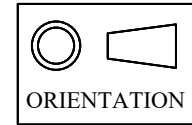

Capacitance	Cap. Tolerance	Dissipation Factor	Rated Voltage	D.W.V.	Rated Current(A)	I.R.(100VDC)	Temp. Coef.	Temp. Range			
10pF	-20%+20%	≤3.0%	6000VDC	7000VDC	15	≥3000MΩ	X7R	-55℃+125℃			
Min. No Load Insertion Loss (dB)@25℃							Install Torque	Soldering Temp	CIRCUIT		
10KHz	100KHz	1MHz	10MHz	100MHz	1GHz	10GHz			≤300℃/3S	C	
--	--	--	--	--	5	15	0.9 N·m				
Material and other parameter note: 1. The case material is silver-plated brass, and the lead material is silver-plated brass. 2. Encapsulated with epoxy resin. 3. The above data is measured under 25℃ conditions, and the electrical performance test frequency is 100KHz/1V. 4. It is recommended to use a soldering iron for soldering. Immersion soldering is strictly prohibited, and the capacitor body must not be struck with hard objects.						Revision Record	160623-01	Product Series	Thread Mount Feedthrough Filters		
							260119-01	LCA [®] made in China	L8060-036		