

PRODUCT DATASHEET

Electrical testing accordance with:
 《GB/T5968-2011》
 《GB/T5966-2011》
 LCA standard test

Do not Scale this Drawing
 Unit : mm

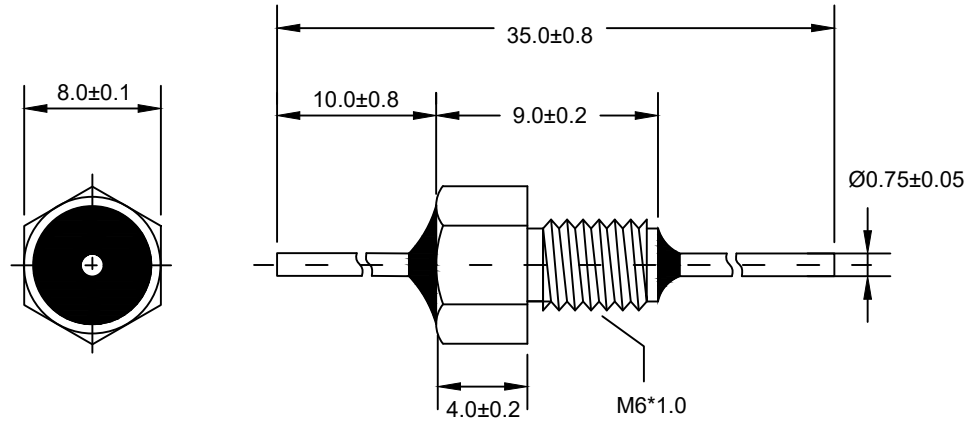
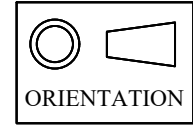

Capacitance	Cap. Tolerance	Dissipation Factor	Rated Voltage	D.W.V.	Rated Current(A)	I.R.(100VDC)	Temp. Coef.	Temp. Range			
1000pF	-20%+80%	≤3.5%	100VDC	630VDC	7	≥3000MΩ	X7R	-55°C +125°C			
Min. No Load Insertion Loss (dB)@25°C							Install Torque	Soldering Temp	CIRCUIT		
10KHz	100KHz	1MHz	10MHz	100MHz	1GHz	10GHz			≤300°C/3S	C	
--	--	--	5	15	30	40	0.9 N·m				
Material and other parameter note: 1. The case material is nickel-plated brass, and the lead material is silver-plated brass. 2. Encapsulated with epoxy resin. 3. The above data is measured under 25°C conditions, and the electrical performance test frequency is 1KHz/1V. 4. It is recommended to use a soldering iron for soldering. Immersion soldering is strictly prohibited, and the capacitor body must not be struck with hard objects.						Revision Record	160623-01	Product Series	Thread Mount Feedthrough Filters		
							260119-01		<h2>L8060-031N</h2>		